

## STEPPER MOTOR CONTROL AND DRIVE SYSTEM FAMILY

### DESCRIPTION

The **GS-DC200** series is a family of single Eurocard boards that contain all the logic necessary to operate a stepper motor, including the instructions decoding, the step timing generation, the storage of the program to be executed. The motor interface can deliver phase current up to 2.5A.

The boards can be used as a stand alone complete motion control system or they can be driven by a central host computer.

The **GS-DC200** family is built around the **GS-C200**, **GS-C200S**, **GS-D200**, **GS-D200S** modules, (see the relevant data sheet) and it retains all the features of these modules.



### SELECTION CHART

| Ordering Number   | Controller Sequencer Driver | Instruction Set Commands | Phase Current (A) |
|-------------------|-----------------------------|--------------------------|-------------------|
| <b>GS-DC200</b>   | GS-C200+GS-D200             | 25                       | 2.0               |
| <b>GS-DC200S</b>  | GS-C200+GS-D200S            | 25                       | 2.5               |
| <b>GS-DC200SS</b> | GS-C200S+GS-D200S           | 29                       | 2.5               |

### ABSOLUTE MAXIMUM RATINGS

| Symbol           | Parameter   | Value       | Unit |
|------------------|---|-------------|------|
| V <sub>s</sub>   | DC Supply Voltage                                 | 42          | V    |
| T <sub>stg</sub> | Storage Temperature Range                         | -40 to +105 | °C   |
| T <sub>hop</sub> | Max Operating Heatsink Temperature (GS-D200/200S) | +85         | °C   |

## GS-DC200 Family

### ELECTRICAL CHARACTERISTICS (T<sub>amb</sub> = 25°C and V<sub>S</sub>=24V unless otherwise specified)

| Symbol           | Parameter                    | Test Conditions          | Min | Typ | Max      | Unit   |
|------------------|------------------------------|--------------------------|-----|-----|----------|--------|
| V <sub>S</sub>   | DC Supply Voltage            |                          | 12  |     | 40       | V      |
| I <sub>S</sub>   | Quiescent Supply Current     |                          |     | 150 |          | mA     |
| V <sub>i</sub>   | Logic Input Voltage          | Low<br>High              | 2   |     | 0.8<br>5 | V<br>V |
| V <sub>O</sub>   | Logic Output Voltage         | Low<br>High              | 2   |     | 0.8<br>5 | V<br>V |
| I <sub>ph</sub>  | Programmable Phase Current   | GS-DC200<br>GS-DC200S/SS |     |     | 2<br>2.5 | A<br>A |
| f <sub>c</sub>   | Chopper Frequency            |                          |     | 17  |          | kHz    |
| t <sub>cpw</sub> | Clock Pulse Width            |                          |     |     | 5        | μs     |
| t <sub>rpw</sub> | Reset Pulse Width (Internal) |                          |     |     | 500      | μs     |

### MOTION CHARACTERISTICS

|                                |                      |
|--------------------------------|----------------------|
| Speed Range                    | 10 to 10000 steps    |
| Speed Resolution               | 10 steps             |
| Ramp Length                    | 1 to 999 steps       |
| Ramp Resolution                | 1 step               |
| Positioning Range (GS-DC200/S) | 0 to 9999999         |
| Positioning Range (GS-DC200SS) | -8388608 to +8388607 |
| Single Movement Range          | 1 to 9999999 steps   |
| Positioning Resolution         | 1 step               |
| Positioning Repeatability      | ± 0 step             |
| Program Storage Capability     | 119 Bytes            |

### COMMUNICATION PORT CHARACTERISTICS

|                 |   |
|-----------------|---|
| SIGNAL LINES    | 3(TXD, RXD, GND)                                      |
| BAUD RATE RANGE | 110 to 9600   |
| FORMAT          | 1 Start Bit<br>7 Data Bit<br>2 Stop Bit<br>Odd Parity |

Figure 1. GS-DC200, GS-DC200S and GS-DC200SS Block Diagram

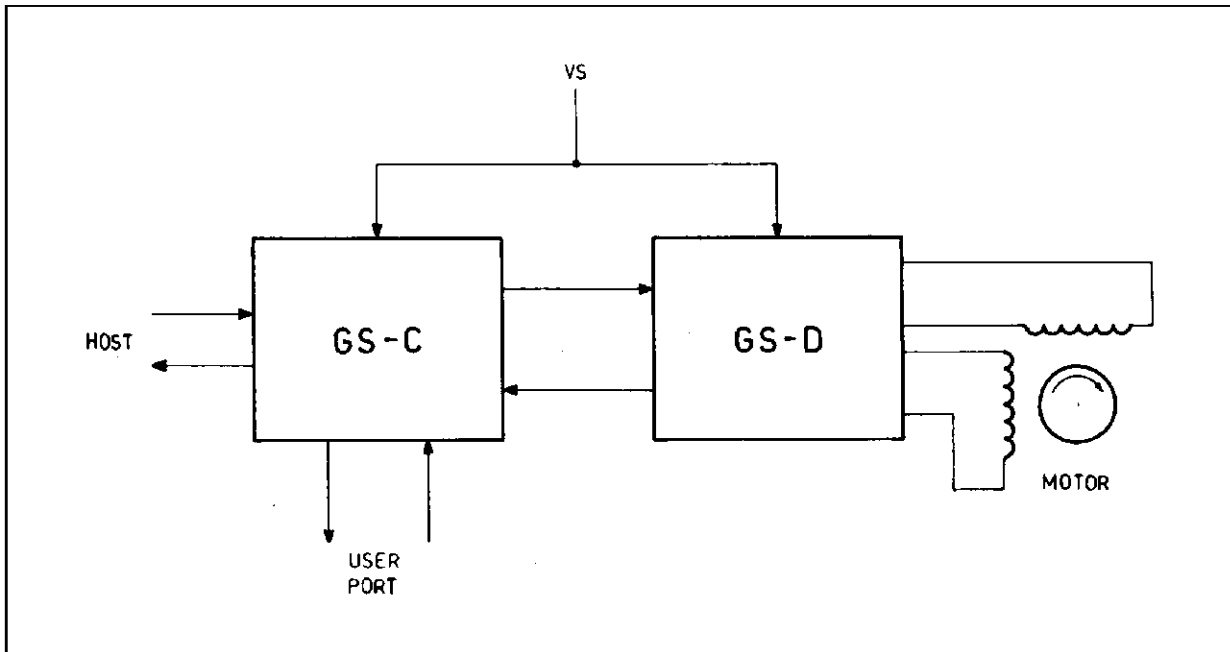
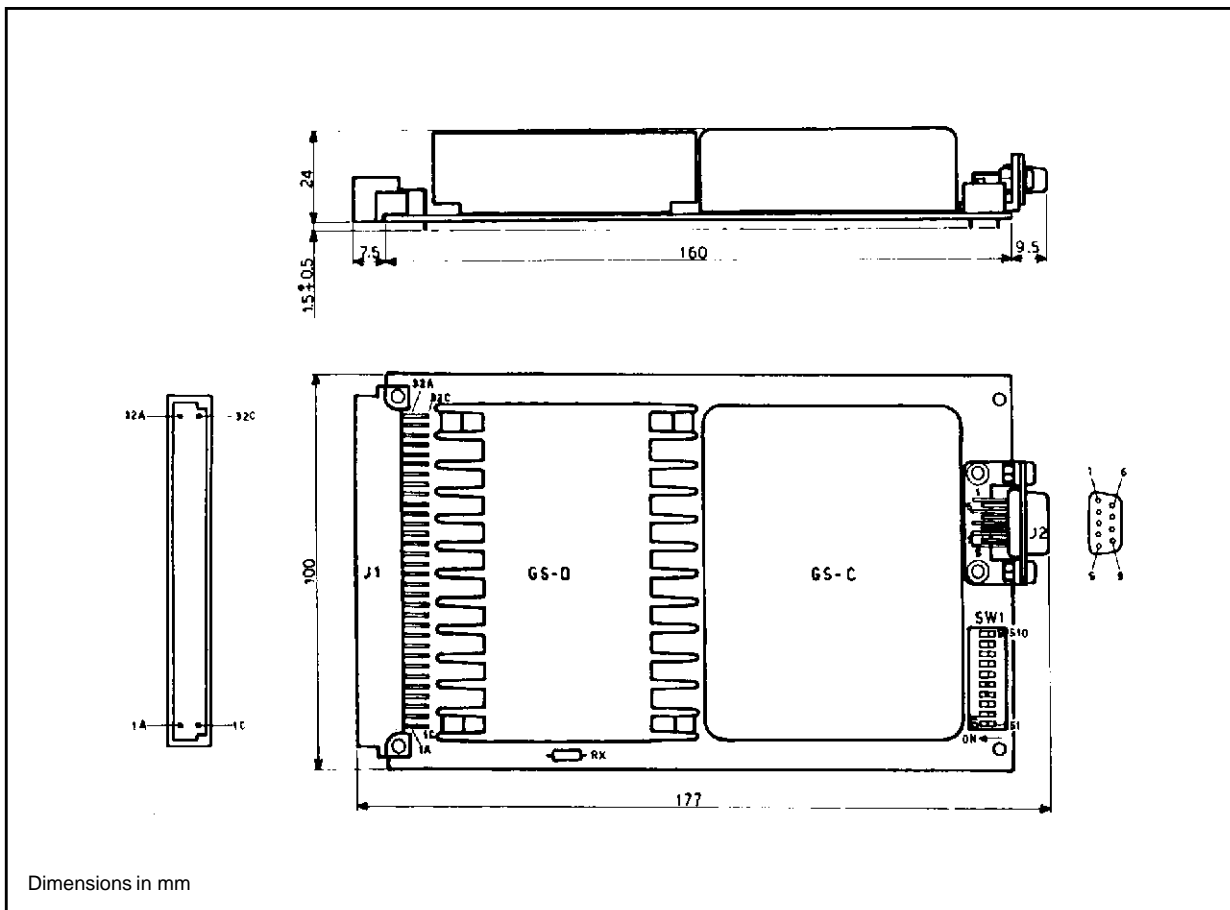

Fig. 2 - GS-DC Stepper Motor Driver/Controller Board



Dimensions in mm

# GS-DC200 Family

Fig. 3 - GS-DC200, GS-DC200S and GS-DC200SS Schematic Diagram

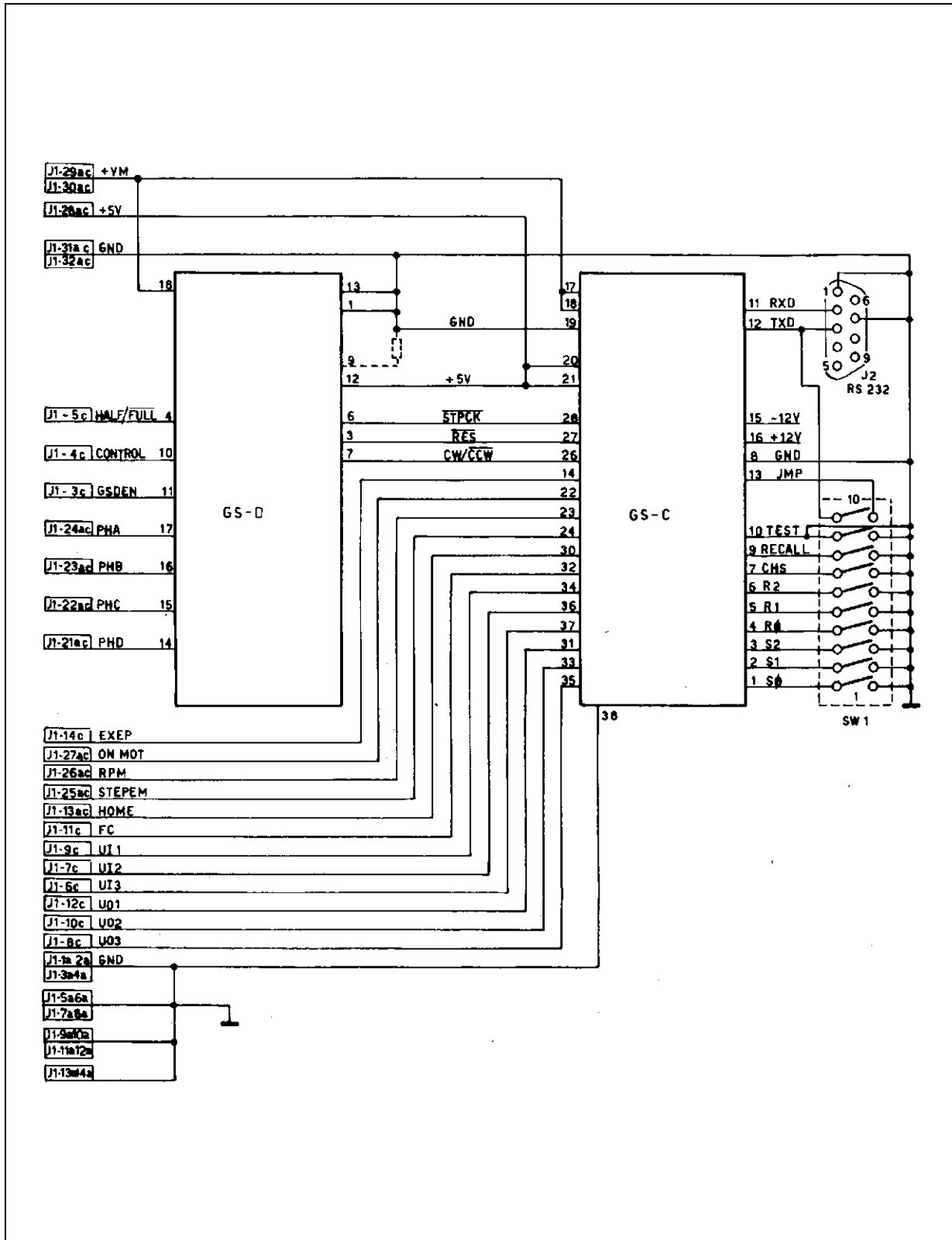

**GS-DC FAMILY BUS CONNECTOR PINS DESCRIPTION**

The GS-DC family uses a 32 pin (16+16) DIN 41612-VG 95324 male connector and a RS-232 connector.

**DIN BUS CONNECTOR (J1)**

| Pin | Row a<br>Signal                | Row c<br>Signal                |
|-----|--------------------------------|--------------------------------|
| 1   | Ground                         | Not used                       |
| 2   | Ground                         | Not used                       |
| 3   | Ground                         | Power driver enable input      |
| 4   | Ground                         | Power driver control input     |
| 5   | Ground                         | Half/Full step select          |
| 6   | Ground                         | User input 3                   |
| 7   | Ground                         | User input 2                   |
| 8   | Ground                         | User output 3                  |
| 9   | Ground                         | User input 1                   |
| 10  | Ground                         | User output 2                  |
| 11  | Ground                         | End-of-travel switch           |
| 12  | Ground                         | User output 1                  |
| 13  | Ground                         | Home switch                    |
| 14  | Ground                         | Prog. underexecution output    |
| 15  | Not used                       | Not used                       |
| 16  | Not used                       | Not used                       |
| 17  | Not used                       | Not used                       |
| 18  | Not used                       | Not used                       |
| 19  | Not used                       | Not used                       |
| 20  | Not used                       | Not used                       |
| 21  | Phase D output                 | Phase D output                 |
| 22  | Phase C output                 | Phase C output                 |
| 23  | Phase B output                 | Phase B output                 |
| 24  | Phase A output                 | Phase A output                 |
| 25  | Step enable input              | Stop enable input              |
| 26  | Ramp in execution logic output | Ramp in execution logic output |
| 27  | Motor moving                   | Motor moving                   |
| 28  | +5V output                     | +5V output                     |
| 29  | Supply voltage                 | Supply voltage                 |
| 30  | Supply voltage                 | Supply voltage                 |
| 31  | Supply ground                  | Supply ground                  |
| 32  | Supply ground                  | Supply ground                  |

## GS-DC200 Family

### RS-232 CONNECTOR (J2 - DB9)

|       |                         |
|-------|-------------------------|
| Pin 1 | Ground                  |
| Pin 2 | Received data input     |
| Pin 3 | Transmitted data output |
| Pin 7 | Ground                  |

### GS-DC FAMILY HARDWARE AVAILABLE COMMANDS

Dip switch configuration selection (0=OFF 1=ON)

| S1 | S2 | S3 | Address | Protocol       |
|----|----|----|---------|----------------|
| 0  | 0  | 0  | –       | Point-to-point |
| 1  | 0  | 0  | 1       | Multipoint     |
| 0  | 1  | 0  | 2       | Multipoint     |
| 1  | 1  | 0  | 3       | Multipoint     |
| 0  | 0  | 1  | 4       | Multipoint     |
| 1  | 0  | 1  | 5       | Multipoint     |
| 0  | 1  | 1  | 6       | Multipoint     |
| 1  | 1  | 1  | 7       | Multipoint     |

| S4 | S5 | S6 | Baud rate |
|----|----|----|-----------|
| 0  | 0  | 0  | 110       |
| 1  | 0  | 0  | 150       |
| 0  | 1  | 0  | 300       |
| 1  | 1  | 0  | 600       |
| 0  | 0  | 1  | 1200      |
| 1  | 0  | 1  | 2400      |
| 0  | 1  | 1  | 4800      |
| 1  | 1  | 1  | 9600      |

| S7 | Checksum |
|----|----------|
| 1  | Disable  |
| 0  | Enable   |

| S8 | Stand alone operation |
|----|-----------------------|
| 1  | Enable                |
| 0  | Disable               |

Note: Switch position 9 is not used.

| S10 | RS232 TXD pull-down |
|-----|---------------------|
| 0   | Not connected       |
| 1   | Connected           |

|    |                                |
|----|--------------------------------|
| Rx | Phase peak current programming |
|----|--------------------------------|

**USER NOTES**

To correctly operate the GS-DC boards family, it is recommended to read the following data sheets: GS-C200/200S; GS-D200/200S; GS-C200 PROG.

**Supply Voltage**

The recommended operating maximum supply voltage must include the ripple voltage on the  $V_s$  supply rail and it must not exceed 40V to avoid permanent damage to the board.

The boards have internal capacitors connected between the supply and ground pins to assure the electrical stability. These capacitors cannot handle high values of current ripple and they would be permanently damaged if the voltage source impedance is not adequately low.

The use of a low ESR, high current ripple, 470µF/50V capacitor located as close as possible to the board is recommended. Suitable units are the Sprague type 672 D or 678 D, the RIFA type PEC 126 or any equivalent unit.

**Board Protections**

The GS-DC200 board is protected against occasional or permanent short circuits to the supply voltage of the phase output pins.

The GS-DC200S and GS-DC200SS are protected also against short circuits to ground or to another phase output.

For the GS-DC200S and GS-DC 200SS the protection is of the latching type i.e. when an overload occurs, the board is automatically disabled. To restart the operations, the supply voltage must be switched off for at least 100 ms.

**Motor Connection**

When long wires are needed to connect a remote motor, it is recommended to use twisted pair cables with a proper cross section to minimize DC losses and RFI problems.

**Phase Current Programming**

The maximum output current/phase can be programmed by changing the value of the  $R_x$  resistor. The factory setting is for maximum current of

1 A GS-DC 200

2 A GS-DC200S / GS-DC200SS.

The new value of  $R_x$  resistor for a different value of maximum phase current I (A) can be calculated according to the following formulas:

**GS-D200**

$I > 1,07$

$$R_x = \left[ \frac{10 - I}{(0.993 * I) - 1} \right] \text{ k}\Omega \quad R_x \geq 8.2\text{K}\Omega$$

$I < 1,07$

$$R_x = \left[ \frac{I}{1 - (0.993 * I)} \right] \text{ k}\Omega$$

**GS-D200S**

$I > 2,11$

$$R_x = \left[ \frac{10 - (0.33 * I)}{(0.473 * I) - 1} \right] \text{ k}\Omega \quad R_x \geq 50\text{K}\Omega$$

$I < 2,11$

$$R_x = \left[ \frac{I}{3.03 - (1,43 I)} \right] \text{ k}\Omega$$

The maximum programmed current must not exceed 2.0A for the GS-DC200 and 2.5A for the GS-DC200S/GS-DC200SS.

**Thermal Characteristics**

The maximum power dissipation occurs on the GS-D200/GS-D200S modules used on the boards. The thermal resistance case-to-ambient of the integral heatsink of these modules is 5°C/W. This means a 50°C temperature increase of the heatsink if the internal power dissipation is 10W.

The maximum allowed heatsink temperature is 85°C. Therefore, according to the ambient temperature and/or the internal power dissipation, forced ventilation may be required.

**Programming**

To correctly program motion sequences, see the GS-C200/200S and/or GS-C200 PROG data sheets.

Information furnished is believed to be accurate and reliable. However, SGS-THOMSON Microelectronics assumes no responsibility for the consequences of use of such information nor for any infringement of patents or other rights of third parties which may result from its use. No license is granted by implication or otherwise under any patent or patent rights of SGS-THOMSON Microelectronics. Specification mentioned in this publication are subject to change without notice. This publication supersedes and replaces all information previously supplied. SGS-THOMSON Microelectronics products are not authorized for use as critical components in life support devices or systems without express written approval of SGS-THOMSON Microelectronics.

© 1994 SGS-THOMSON Microelectronics – All Rights Reserved

SGS-THOMSON Microelectronics GROUP OF COMPANIES  
 Australia - Brazil - China - France - Germany - Hong Kong - Italy - Japan - Korea - Malaysia - Malta - Morocco - The Netherlands - Singapore - Spain - Sweden - Switzerland - Taiwan - Thailand - United Kingdom - U.S.A.